

# Brickapalooza

Volume 1, Issue 1

July 2010

## Welcome to Brickapalooza

*For the Parents of LEGO® Obsessed Children*

**Eric Kingsley**

*Brickapalooza Founder*

Welcome to the first issue of the Brickapalooza newsletter. In combination with brickapalooza.com we hope to help you understand why your child is so obsessed with LEGO and how to manage that obsession. LEGO is a wonderfully educational toy but at times frustrating for both the children who use it and their parents.

Children often get frustrated just finding a part for a large set. This generally means someone has to sit and help them find the pieces they need. While this can be a great bonding experience you may like ideas on how to get your child to manage this process themselves.

On the other hand parents get frustrated when LEGO becomes more likely to be stepped on than the floor itself. This is an admittedly frustrating situation but it can be managed by finding the solution that works best with your child.

*continued on page 2*

## INSIDE THIS ISSUE

- 1 Welcome to Brickapalooza
- 1 Subscription Benefits
- 2 Deal of the Month
- 3 Model Idea of the Month
- 4 Set Review
- 4 Questions and Answers

## Subscription Benefits

*How much does it cost and what do I get.*

Cost: \$10/year

Benefits include:

- 12 issues of the Brickapalooza newsletter (Downloaded from brickapalooza.com)
- Exclusive content on Brickapalooza.com
- Access to members only forums
- Ability to submit questions
- Submit editorial content for the newsletter
- Request specific building ideas
- Request specific set reviews
- LEGO buying tips
- Storage ideas

With the exception of some promotional items nearly all

*The goal of a subscription is that you will be better able to understand and manage your child's LEGO obsession and their collection.*

Brickapalooza content will be by subscription only. Subscriptions can be purchased in one year increments at [brickapalooza.com](http://brickapalooza.com) after signing up for an account.

The goal of a subscription is that you will be better able to understand and manage your child's LEGO obsession and their collection. Present your child with instructions that will stimulate ideas. Find ideas for LEGO storage that work for children and make clean up easier for you.

*continued on page 4*

Some children and parents look at LEGO as building sets and nothing more. They build a set and that is all there is. After some hard play or frustrated parents picking up models and tossing them in the toy box parts get separated and eventually it becomes extremely difficult to put the model back together again.

Don't think of this as a ruined toy, think of this as an opportunity to add to your free build collection. LEGO's roots are in free play. What this means is the child uses their imagination together with a pile of LEGO Bricks to build something fun and unique. That is one of the wonderful things about LEGO, it is infinitely recyclable. One moment you have a car, then those same parts can be repositioned and a few moments later you have a plane, spaceship, or a boat. All without having to spend money on each of those toys individually.

---

*With LEGO your child can have a new toy every day of the year.*

---

### Who am I?

My name is Eric Kingsley I am 40 years old and I have been an adult LEGO fan for over 11 years. I currently have a 9 year old son and a 7 year old daughter. Both are huge LEGO fans in their prime LEGO building years.

I helped to form the New England LEGO Users Group back in 1999. NELUG is an adult LEGO group. We have over 60 paid members and have public displays at shows throughout New England.

Being an adult builder I enjoy the hobby in different ways then children but being a parent of 2 LEGO maniacs I have many of the same frustrations that you do and sometimes more.

My collection is sorted by individual part type to make it easier to find parts. My kids love this and in turn enjoy building with dads bricks over their own which tends to "unsort" my LEGO quite quickly.

They also have trouble keeping LEGO off the floor and we constantly are having "Pick up dads LEGO area" sessions which usually involve throwing all the brick in a bin to be sorted later by me.

### What do I think I can do for you?

I see LEGO from many angles as a fan and as a parent. I have seen things that work and things that don't. Not every idea I have or suggestion will work for you and your child

but our hope is to find ways to better manage your child's collection as well as stimulate them to use their imaginations.

Long term family building projects can be a great way to bond as a family. I have many ideas to make this work. The biggest challenge is giving kids small chunks so they can see progress and have fun without getting board and losing interest.

Often as children get older there is a time where they feel their only LEGO outlet is through robotics. While this is a fantastic product not every child is interested in robotics. Some may be more interested in architecture or sculpting in a different medium. They need to be encouraged and not made to feel like LEGO is off limits because it is a child's toy.

I will also offer a question and answer facility where we can all learn from each other's challenges. You may have an issue about organizing your child before they build that brand new \$100 castle. Or you may want to find a way that allows you to efficiently pick up the LEGO without dissuading your child from using LEGO.

We all love our children and LEGO is a fun and very educational toy. It is as relevant now as it was 30-40 years ago. If you still have some of the LEGO from your childhood lying around it still works with the LEGO of today. We all need to encourage our young builders while maintaining our own sanity. ❖

### DEAL OF THE MONTH



Originally ~~\$69.99~~ now **\$48.98** at LEGO Shop at Home. This Technic set has 575 pieces and is rated for children 9-16. At prices like this the parts become more valuable than the set. If you have a robotics builder this is a great expansion set for them.

## MODEL IDEA OF THE MONTH

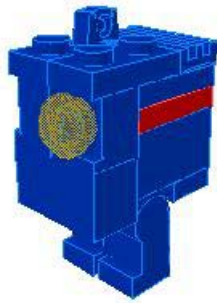

Gonk Robot

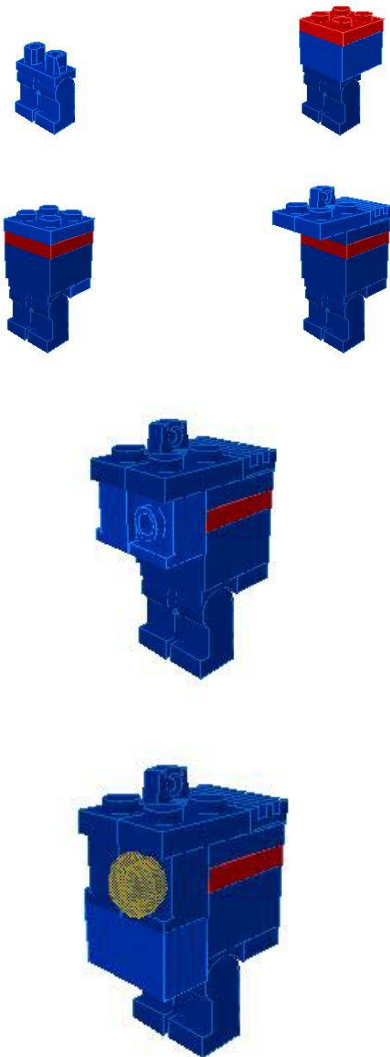

### What we Ask of You

We ask that you recommend Brickapalooza to others and don't share the newsletter freely. The reason for this is simple; I want to be able to focus as much effort into this as I can. If I have relatively few paid subscriptions then the motivation for me won't be there, not to mention the funds needed to support buying sets for review and doing research.

In each of our newsletters and on the Brickapalooza web site we will have links to products on-line. Some of these links, but not all, will pay us a small percentage for orders placed after clicking those links. While not significant every bit helps and you pay the same whether you use our link or not.

Word of mouth and the support of satisfied readers are ultimately what will make this a success. Please feel free to offer suggestions on our web site.

### Our Commitment to You

With the issuance of the first issue of the Brickapalooza newsletter I am committing to a full year of issues. The success of the newsletter will determine if a commitment for a second year is appropriate.

Should events dictate an early end to the newsletter a prorated portion of your subscription may be returned to you. We do not anticipate this happening but life throws us curves from time to time.

### Other Promises

- No set will be reviewed based on perception alone. All reviewed sets will have been purchased and assembled in order to give a full and accurate.
- We will not do a significant review of any set under \$10.
- We will try and answer all questions as thoughtfully as possible.
- While focused on the LEGO System of Play we will try and have relevant content for all LEGO age groups. If we are not addressing your needs please ask questions.
- I will always give you my unbiased opinion. If I don't like a set or other LEGO product I will tell you and will let you know why.

## REVIEW 3179-REPAIR TRUCK



Item #: 3179  
Ages: 5-12  
Pieces: 118  
Price \$12.99

[Purchase this set](#)

This is a nice small set with. The set comes with a lot of tools, a garbage can, a lamp, and a man lift of the truck. This gives this set a very high playability rating. Building the set was not terribly challenging but was fun. Not many repeated steps which can frustrate a young builder. I have a big problem with all the stickers LEGO uses on sets now. They are very difficult for little hands to apply. I understand it is a cost cutting measure but there doesn't have to be that many stickers.



## LEGO Terminology

*Sometimes official sometimes childish but now you know.*

Studs: The cylindrical “bumps” on the top of all standard LEGO bricks. This is one half of the original clutch system that holds most LEGO parts together.

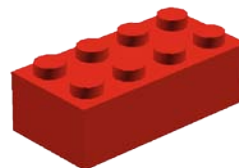

Tubes: These are the cylindrical “tubes” on the bottom of all standard 2 stud or wider brick. These are the other half of the basic LEGO clutch system.



Each month we will highlight other LEGO terminology. ❖

## QUESTIONS AND ANSWERS

Q: How frequently can I expect a new newsletter to be available?

A: We are planning one newsletter per month. We don't have a set publish date although our intention is the middle third of each month.

Q: Do I need a Brickapalooza.com account to receive the newsletter?

A: Yes. The Brickapalooza.com site is an extension of this newsletter where you can help direct the content of future editions.

Q: Can we expect anything more out of Brickapalooza other than the

newsletter and web site?

A: Initially probably not although we have many ideas. It all depends on what is desired and our ability to deliver.

Q: Can you help me clean up all this LEGO?

A: Physically no, sorry but I have lots of ideas that you can try with your child to keep that LEGO confined to a small area. That doesn't mean a part won't escape here and there but there are ways to organize that massive pile of brightly colored bricks.

Q: If I have an idea how do I share it?

A: I will be setting up forums as well as question and answer forms at the

brickapalooza website. You can discuss your ideas with other parents and myself in the forums or direct a question more directly at me to be addressed in this newsletter.

Q: Can I cancel my subscription?

A: If you are terribly unsatisfied I will do my best to make good on your investment. Please understand that I am an individual just trying to make this work and I don't have the resources to offer refunds at any time. We feel like \$10 for 12 newsletter issues and access to exclusive content on our web site is more than reasonable. ❖